

752V Diaphragm Valve

Compact diaphragm valve for fine flow control



Ideal for dispensing controlled amounts of most low-to medium viscosity fluids.

The 752V Series dispense valve systems accurately control the application of most low to medium viscosity fluids. The unique seal-less design incorporates an inert polymer diaphragm that isolates the actuator from the valve.

Valve open time can be as short as 15 milli-seconds. The adjustable open/close stroke 0.13 to 0.64 mm (0.005" to 0.025") means very fast response and positive shutoff.

Model 752V-UHSS with UHMW* polymer wetted parts is used for dispensing solvents, cyanoacrylates, anaerobics and fluxes.

A light blocking acetal valve chamber on the 752V-SS provides consistent, bubble-free dispensing of UV-cure polymers.

*Ultra High Molecular Weight polyethylene



752V filling cans with electrolytes.

"After 100 million cycles, we took the 752V-UH apart to check it. No repairs or parts needed. Reassembled and had it back in operation in about 5 minutes."

Remington Arms

Features and Benefits

- Compact size and weight
- Adjustable fluid flow control
- Positive shutoff, no seals
- Diaphragm life exceeds 100 million cycles
- Easy cleaning
- FDA-compliant wetted parts
- Cycle rate exceeds 500/minute
- Low-maintenance design

Part #	Description
7021428	752V-UHSS Valve: UHMW fluid body and diaphragm
7021419	752V-SS Valve: Acetal copolymer fluid body and UHMW diaphragm
7021411	752V-DVD Valve: Tamper-resist stroke adjustment UHMW diaphragm and 303 stainless steel fluid body
7015582	752V-SS-BP Valve: Acetal copolymer fluid body and UHMW diaphragm
7015583	752V-UHSS-BP Valve: UHMW fluid body and diaphragm



more info



Specifications

Item	Product
Size	752V-UHSS / 752V-SS: 80.7L x 26.9DIA mm (3.18L x 1.06DIA") 752V-DVD: 76.3L x 26.9DIA mm (3.00L x 1.06DIA")
Weight	752V-UHSS: 173.6 g (6.1 oz) 752V-SS: 181.4 g (6.4 oz) 752V-DVD: 172.9 g (6.1 oz)
Actuating air pressure required	4.8–6.2 bar (70–90 psi)
Maximum fluid pressure	4.8 bar (70 psi)
Fluid inlet	1/8 NPT female
Fluid outlet	1/4-28 UNF
Mounting	(1) 10-32 UNF tapped hole
Cycle rate	Exceeds 500 per minute
Air cylinder body	303 stainless steel 752V-DVD: Hard-coated anodized aluminum
Fluid body	752V-UHSS: UHMW* polyethylene, FDA approved Options: Acetal, 303 stainless steel, PTFE
Piston	303 stainless steel
Diaphragm	FDA approved UHMW polyethylene or PTFE
Tip adapter	Polypropylene
Tip retaining nut	752V-DVD: Aluminum
Maximum operating temperature	43° C (110° F)
Warranty	1 year, limited

All stainless steel parts are passivated.

*Ultra High Molecular Weight polyethylene

Diaphragm Valve Systems

The complete system includes the 752V Series valve, ValveMate™ 8000 controller, the fluid reservoir and dispense tip.

Expert technical assistance and high quality standards ensure productive, trouble-free performance. Nordson EFD offers a full line of reliable dispensing systems to meet your specific application requirements.

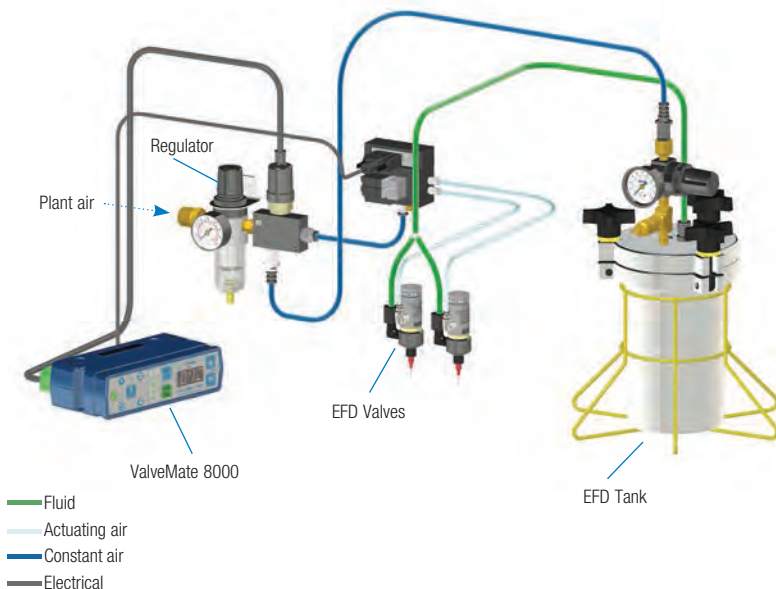

752V Series Valves

The 752V Series valves are used with ValveMate 8000 controllers or Nordson EFD Automated System for precise, repeatable outputs of low to medium viscosity fluids.

The 752V Series wetted components are inert plastics and use the same actuating assembly and diaphragm. Each valve can be calibrated with the stroke reference knob for process control.

The amount dispensed depends on valve open time, fluid pressure, fluid viscosity, flow adjustment and tip size.

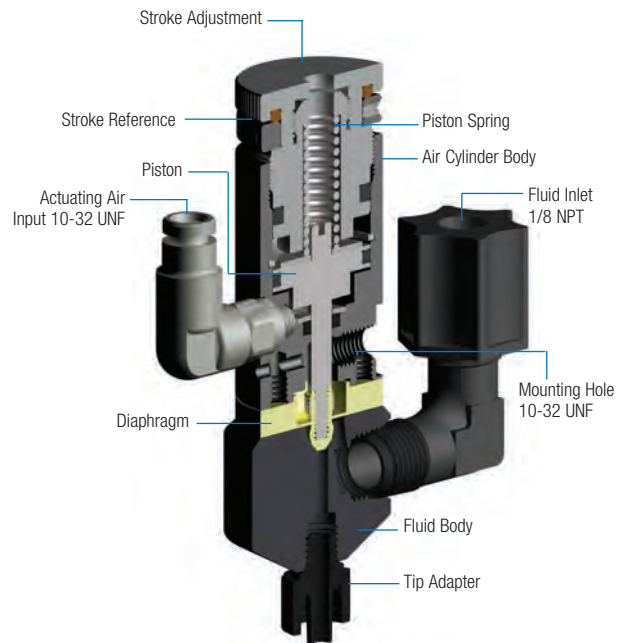

ValveMate 8000 Controller

Valve open time is the primary control of deposit size. The ValveMate controller puts push-button adjustment of valve open time where it needs to be — at the valve.

- Multi-valve control- up to (4) valves
- Partner to Programmable Logic Controller (PLC)
- Easy deposit size control
- Increased production output
- End user convenience
- On-the-fly adjustability
- Maximum machine efficiency

Automated Dispensing Systems

Nordson EFD offers a wide range of automated systems that are fully compatible with the 752V Series valve. Our automated systems offer consistent, accurate, and repeatable performance, making even the most complex dispensing applications easy. Get simplified setup and programming plus optimized dispensing results from features such as laser height sensing and fully integrated CCD cameras, or specify inline systems designed for larger products.

Fluid Reservoirs

Nordson EFD reservoirs are supplied with precision, constant bleed regulators to ensure consistent fluid pressure to the valve. Tank reservoirs are available in 1.0, 5.0, and 19.0 liter capacities. Optimum® systems are available with 2.5 oz to 32 oz (75 ml to 950 ml) cartridges and retainers.

Note: The 1.0 liter tank accepts a 1 lb bottle of cyanoacrylate.

Dispense Tips

Tip selection is critical to achieve optimum valve performance. 752V Series valves are packaged with a dispensing tip kit for maximum fluid control. The kit includes SmoothFlow™ tapered tips in sizes from 14 to 25 gauge, precision stainless steel tips in sizes from 14 to 21 gauge, and tip caps.

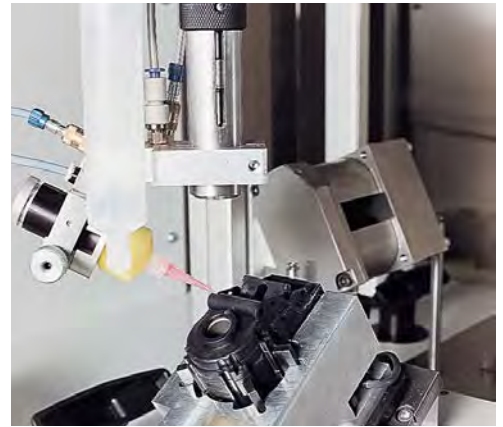

752V dispensing cyanoacrylate on electric car mirror.



752V valve on robot dispensing on PCB.



752V dispensing uv-cure adhesive on medical pump.

Request a Process Evaluation

Contact Nordson EFD to configure a precision dispense system that meets your specific needs, with:

- A complimentary process evaluation by experienced fluid dispensing experts.
- Samples processed for customer evaluation and approval prior to purchase.

800-556-3484; info@nordsonefd.com

Connect with us



For Nordson EFD sales and service in over 40 countries, contact Nordson EFD or go to www.nordsonefd.com.

Global

800-556-3484; +1-401-431-7000
info@nordsonefd.com

Europe

00800 7001 7001
infoefd.europe@nordsonefd.com

Asia

China: +86 (21) 3866 9006; china@nordsonefd.com
India: +91 80 4021 3600; india@nordsonefd.com
Japan: +81 3 5762 2760; japan@nordsonefd.com
Korea: +82-31-736-8321; korea@nordsonefd.com
SEAsia: +65 6796 9522; sin-mal@nordsonefd.com

©2022 Nordson Corporation v020922